

规格/TECHNICAL SPECIFICATIONS

型号/MODEL NUMBER:	I LENS888-S23-1020-H
尺寸/DIMENSIONS:	Φ23.9MM
高度/HEIGHT:	12.5MM
定位方式/FASTENING:	打胶/贴胶/定位柱/Tape or Pin
是否符合ROHS/ROHS COMPLIANT:	是/YES

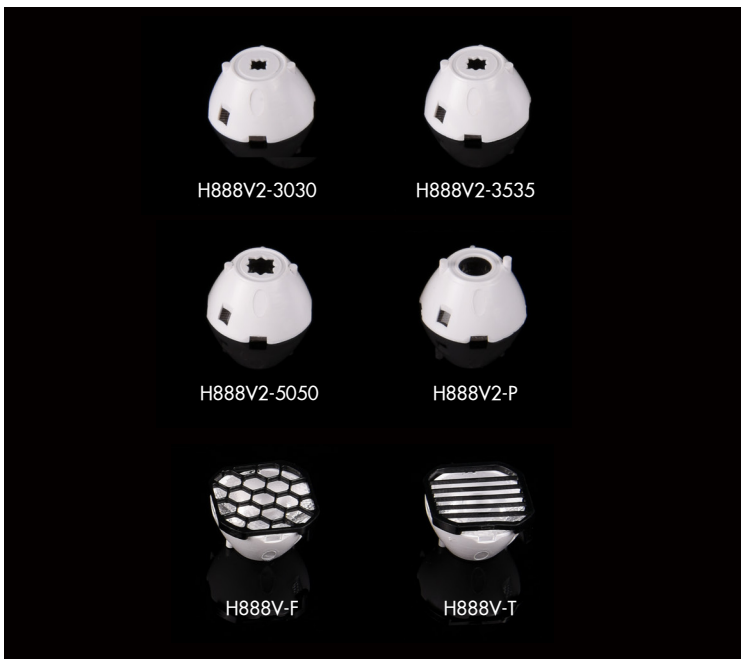

支架零件号/Holder Part No.	颜色/Colour	规格/Specification	功能/Function	固定/Fastening
H888H1-3030 H888H2-3030	黑色/Black 白色/White		适配3030 LED/Suit for 3030 LEDs	打胶/贴胶 Tape
H888V1-3030 H888V2-3030	黑色/Black 白色/White			
H888H1-3535 H888H2-3535	黑色/Black 白色/White		适配3030 LED/Suit for 3535 LEDs	
H888V1-3535 H888V2-3535	黑色/Black 白色/White			
H888H1-5050 H888H2-5050	黑色/Black 白色/White		适配3030 LED/Suit for 5050 LEDs	
H888V1-5050 H888V2-5050	黑色/Black 白色/White			
H888V1-P H888V2-P	黑色/Black 白色/White		适配3030、3535 或5050 LED Suit for 3030 3535 5050 LEDs	定位柱 PINS
H888V1-P-T H888V2-P-T	黑色/Black		适配3030、3535 或5050 LED Suit for 3030 3535 5050 LEDs	
H888V1-P-F H888V2-P-F			降低炫光值 Lower UGR value	

说明/CHARACTERISTIC:

1. 透镜有八种不同的配光角度和三种表面处理。
The lens have 8 types beam angles and with three different surfaces treatment.
2. 多种不同的支架来匹配不同LED, 贴胶或者定位柱定位安装。
With different types brackets to match different leds, Self-adhesive tape or pins for fix.
3. 兼容多种灯珠。
Compatible with various lamp beads.
4. 适用于洗墙灯和投光灯。
Suitable for wall washing lighting and floodlights.
5. 与市面上同类镜头相比, 光效更好, 光斑更漂亮, 兼容性更好。
Compared with similar type lenses on the market,with better light effect ,more beautiful spot and better compatibility.

应用场景/APPLICATION

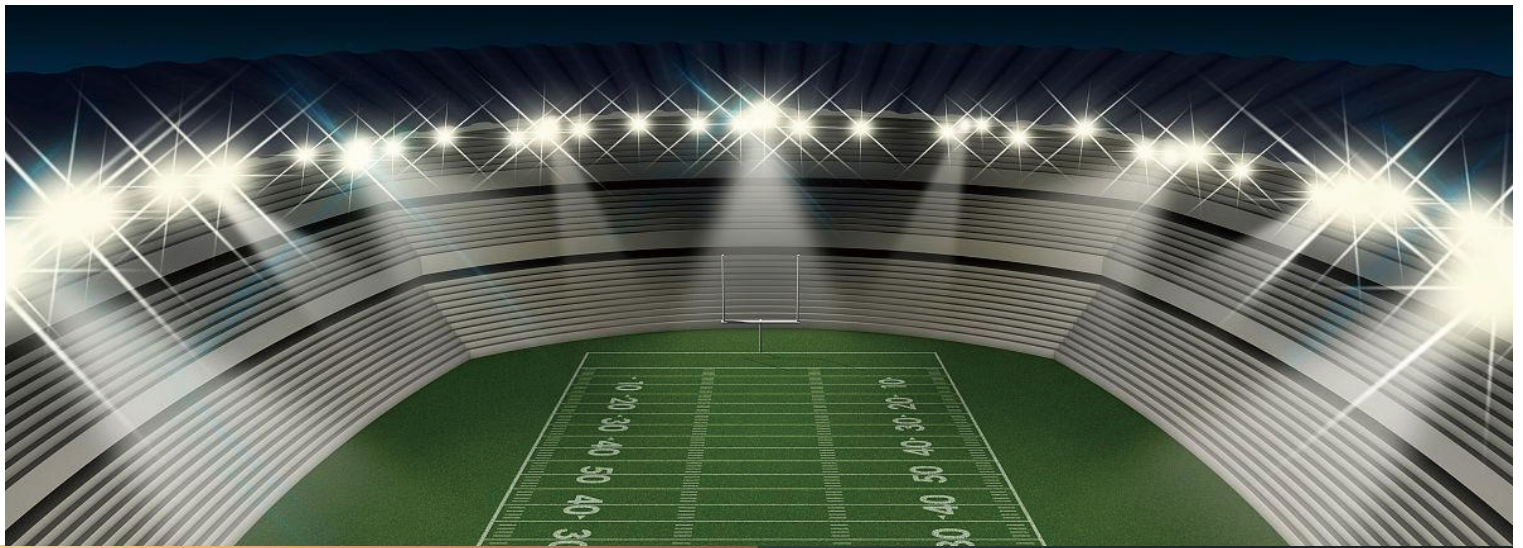

LED:CREE XPE2
 角度/FWHM:10°21°
 光效/Efficiency:90%
 峰值强度/Peakintensity:11CD/LM
 光学面数量/LED/each optic:1
 灯光颜色/Light colour:白色/White
 所需组件/Required components: :

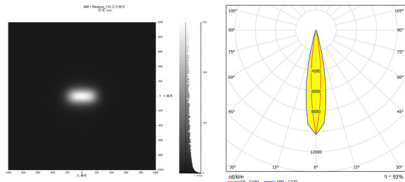

LED:LUMINUS SST20
 角度/FWHM:12°21°
 光效/Efficiency:80%
 峰值强度/Peakintensity:10.3CD/LM
 光学面数量/LED/each optic:1
 灯光颜色/Light colour:白色/White
 所需组件/Required components: :

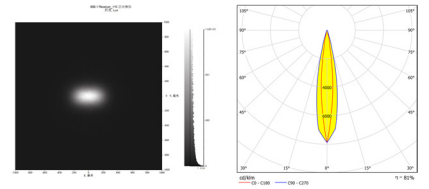

LED:CREE XPG2
 角度/FWHM:11°46°
 光效/Efficiency:90%
 峰值强度/Peakintensity:10CD/LM
 光学面数量/LED/each optic:1
 灯光颜色/Light colour:白色/White
 所需组件/Required components: :

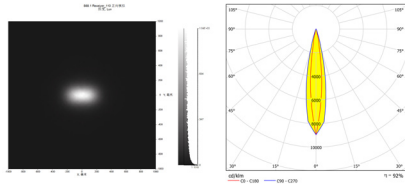

LED:LUMILEDS 5050
 角度/FWHM:15°22°
 光效/Efficiency:65%
 峰值强度/Peakintensity:6.8CD/LM
 光学面数量/LED/each optic:1
 灯光颜色/Light colour:白色/White
 所需组件/Required components: :

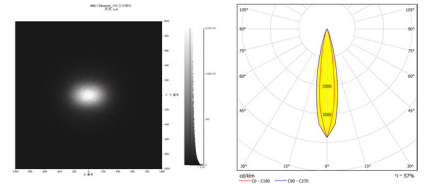

LED:CREE XHP35
 角度/FWHM:16°23°
 光效/Efficiency:83%
 峰值强度/Peakintensity:5.7CD/LM
 光学面数量/LED/each optic:1
 灯光颜色/Light colour:白色/White
 所需组件/Required components: :

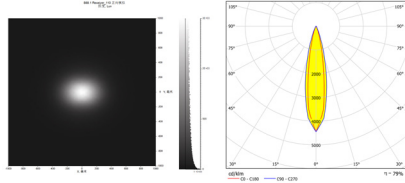

LED:LUMILEDS 3030
 角度/FWHM:10°21°
 光效/Efficiency:83%
 峰值强度/Peakintensity:10.2CD/LM
 光学面数量/LED/each optic:1
 灯光颜色/Light colour:白色/White
 所需组件/Required components: :

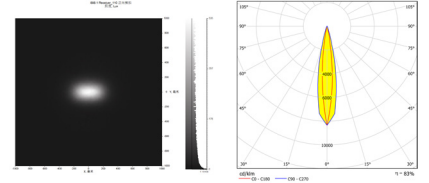

LED:CREE XTE
 角度/FWHM:11°21°
 光效/Efficiency:84%
 峰值强度/Peakintensity:9.1CD/LM
 光学面数量/LED/each optic:1
 灯光颜色/Light colour:白色/White
 所需组件/Required components: :

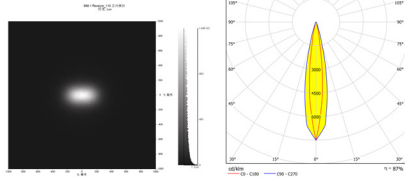

LED:SEOUL SZ5
 角度/FWHM:14°22°
 光效/Efficiency:90%
 峰值强度/Peakintensity:7.6CD/LM
 光学面数量/LED/each optic:1
 灯光颜色/Light colour:白色/White
 所需组件/Required components: :

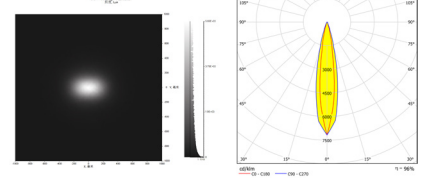

CAD

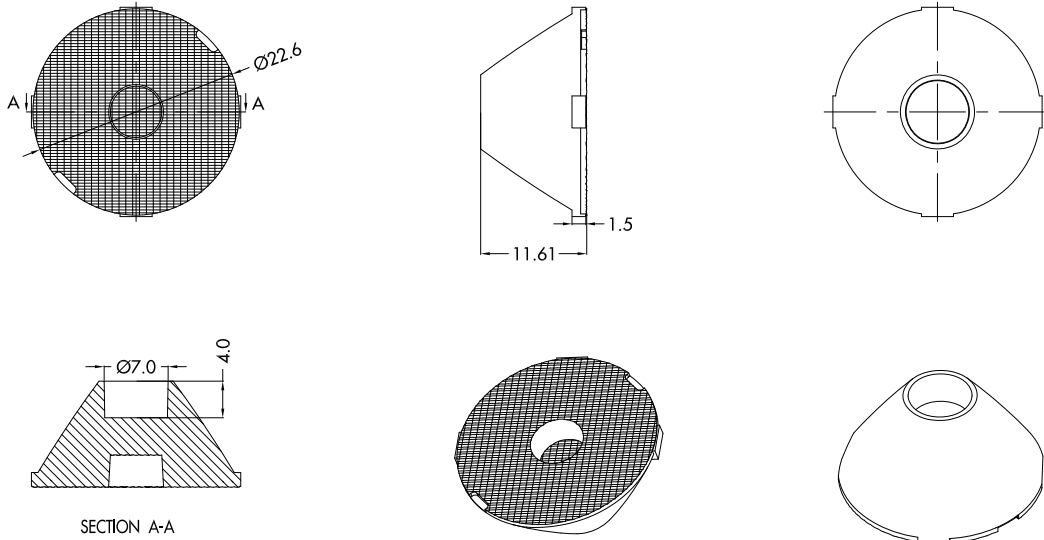

注意/NOTE:

- 1. 镜片表面应光滑无划痕、气泡、凹痕和黑点。
 The surface of the lens should be smooth without scratches, bubbles, dents and black spots.

GENERAL TOLERANCES ISO2768-M (UNLESS STATED) 一般公差ISO 2768-M (除非另有说明)	MATERIAL 材质	PMMA	DRAWING TITLE 绘图标题	ILENS888-S23-1020-H		
LINEAR/线性	0.5 ≤ X ≤ 3.0	±0.1	3.0 ≤ X ≤ 6.0	±0.1	6.0 ≤ X ≤ 30.0	±0.2
ANGULAR/角度	0° ≤ X ≤ 10°	±0.1°	10° ≤ X ≤ 50°	±30'	50° ≤ X ≤ 120°	±20'

H888H-3030

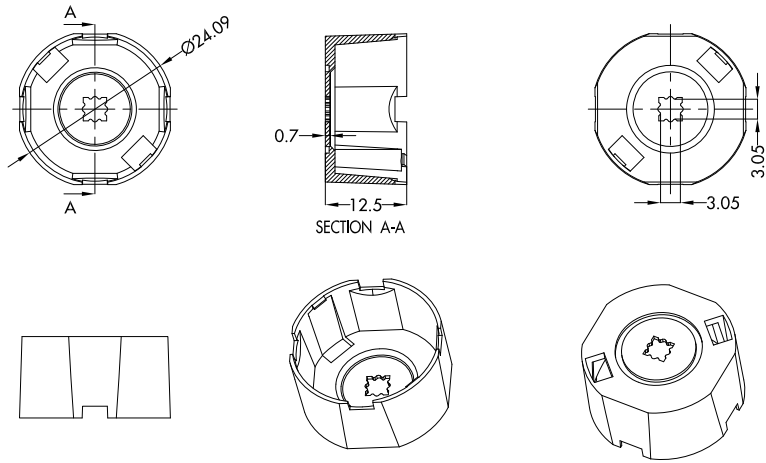

注意/NOTE:

1. 镜片表面应光滑无划痕、气泡、凹痕和黑点。

The surface of the lens should be smooth without scratches, bubbles, dents and black spots.

MATERIL	PC
LINEAR	
$0.5 \leq X \leq 3.0$	± 0.1
$3.0 \leq X \leq 6.0$	± 0.1
$6.0 \leq X \leq 30.0$	± 0.2
ANGULAR	
$0^\circ \leq X \leq 10^\circ$	$\pm 1^\circ$
$10^\circ \leq X \leq 50^\circ$	$\pm 30'$
$50^\circ \leq X \leq 120^\circ$	$\pm 20'$

H888H-3535

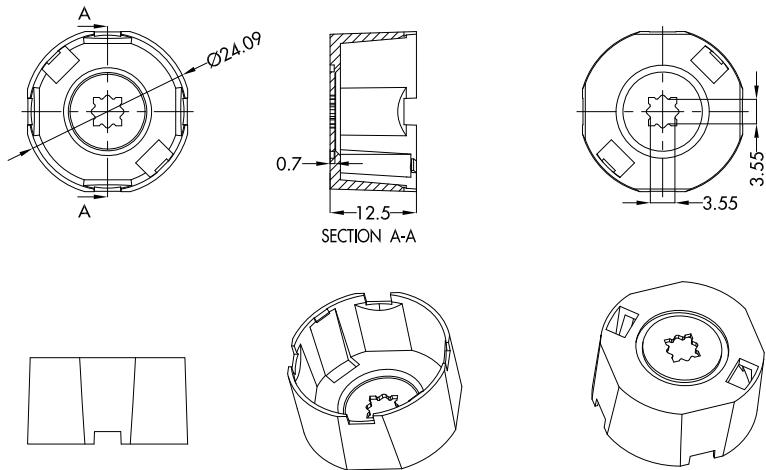

注意/NOTE:

1. 镜片表面应光滑无划痕、气泡、凹痕和黑点。

The surface of the lens should be smooth without scratches, bubbles, dents and black spots.

MATERIL	PC
LINEAR	
$0.5 \leq X \leq 3.0$	± 0.1
$3.0 \leq X \leq 6.0$	± 0.1
$6.0 \leq X \leq 30.0$	± 0.2
ANGULAR	
$0^\circ \leq X \leq 10^\circ$	$\pm 1^\circ$
$10^\circ \leq X \leq 50^\circ$	$\pm 30'$
$50^\circ \leq X \leq 120^\circ$	$\pm 20'$

H888H-5050

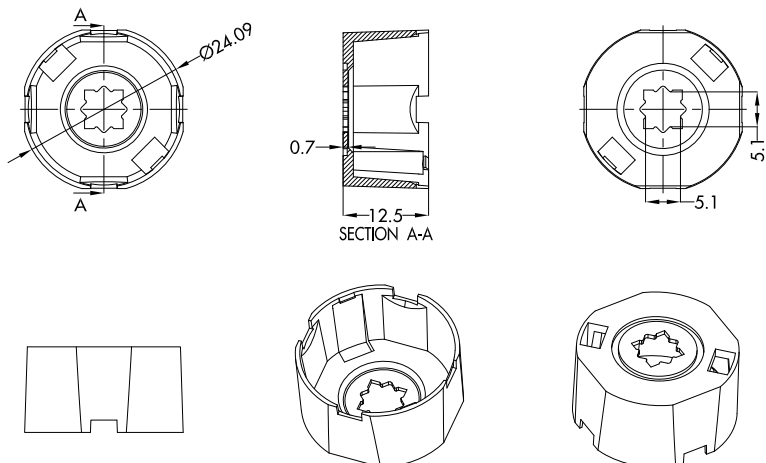

注意/NOTE:

1. 镜片表面应光滑无划痕、气泡、凹痕和黑点。

The surface of the lens should be smooth without scratches, bubbles, dents and black spots.

MATERIL	PC
LINEAR	
$0.5 \leq X \leq 3.0$	± 0.1
$3.0 \leq X \leq 6.0$	± 0.1
$6.0 \leq X \leq 30.0$	± 0.2
ANGULAR	
$0^\circ \leq X \leq 10^\circ$	$\pm 1^\circ$
$10^\circ \leq X \leq 50^\circ$	$\pm 30'$
$50^\circ \leq X \leq 120^\circ$	$\pm 20'$

H888V-3030

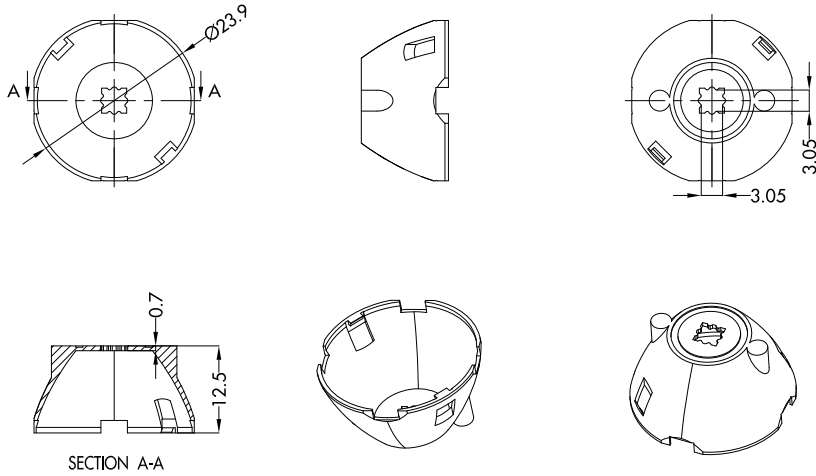

注意/NOTE:

1. 镜片表面应光滑无划痕、气泡、凹痕和黑点。

The surface of the lens should be smooth without scratches, bubbles, dents and black spots.

MATERIL	PC
LINEAR	
$0.5 \leq X \leq 3.0$	± 0.1
$3.0 \leq X \leq 6.0$	± 0.1
$6.0 \leq X \leq 30.0$	± 0.2
ANGULAR	
$0^\circ \leq X \leq 10^\circ$	$\pm 1^\circ$
$10^\circ \leq X \leq 50^\circ$	$\pm 30'$
$50^\circ \leq X \leq 120^\circ$	$\pm 20'$

H888V-3535

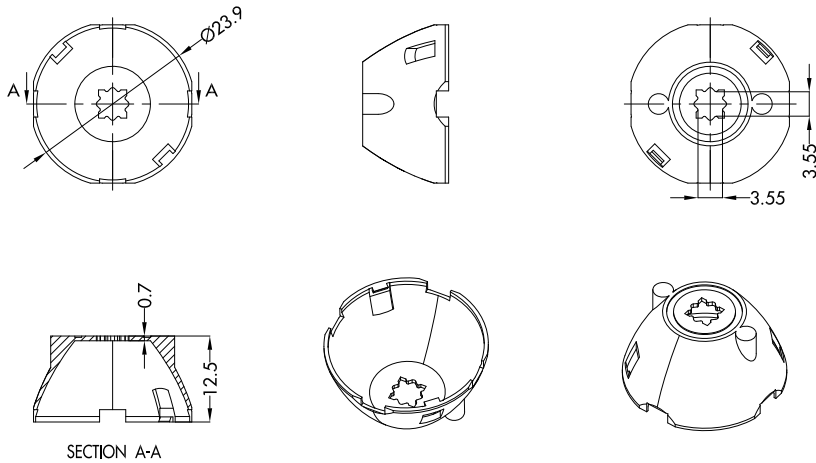

注意/NOTE:

1. 镜片表面应光滑无划痕、气泡、凹痕和黑点。

The surface of the lens should be smooth without scratches, bubbles, dents and black spots.

MATERIL	PC
LINEAR	
$0.5 \leq X \leq 3.0$	± 0.1
$3.0 \leq X \leq 6.0$	± 0.1
$6.0 \leq X \leq 30.0$	± 0.2
ANGULAR	
$0^\circ \leq X \leq 10^\circ$	$\pm 1^\circ$
$10^\circ \leq X \leq 50^\circ$	$\pm 30'$
$50^\circ \leq X \leq 120^\circ$	$\pm 20'$

H888V-5050

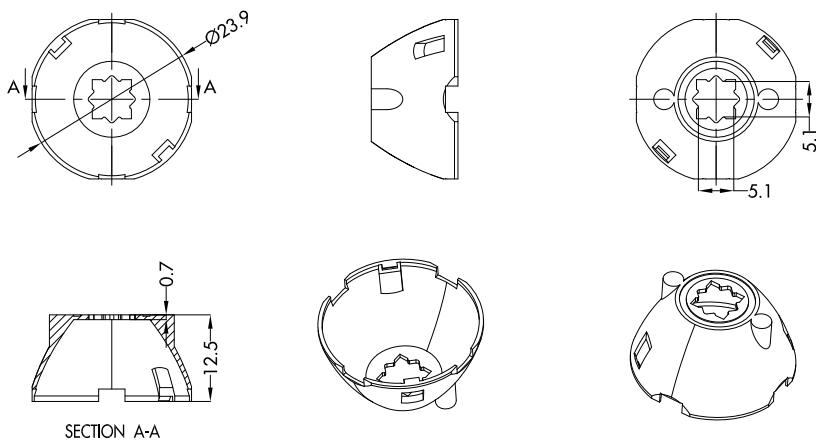

注意/NOTE:

1. 镜片表面应光滑无划痕、气泡、凹痕和黑点。

The surface of the lens should be smooth without scratches, bubbles, dents and black spots.

MATERIL	PC
LINEAR	
$0.5 \leq X \leq 3.0$	± 0.1
$3.0 \leq X \leq 6.0$	± 0.1
$6.0 \leq X \leq 30.0$	± 0.2
ANGULAR	
$0^\circ \leq X \leq 10^\circ$	$\pm 1^\circ$
$10^\circ \leq X \leq 50^\circ$	$\pm 30'$
$50^\circ \leq X \leq 120^\circ$	$\pm 20'$

H888V-F

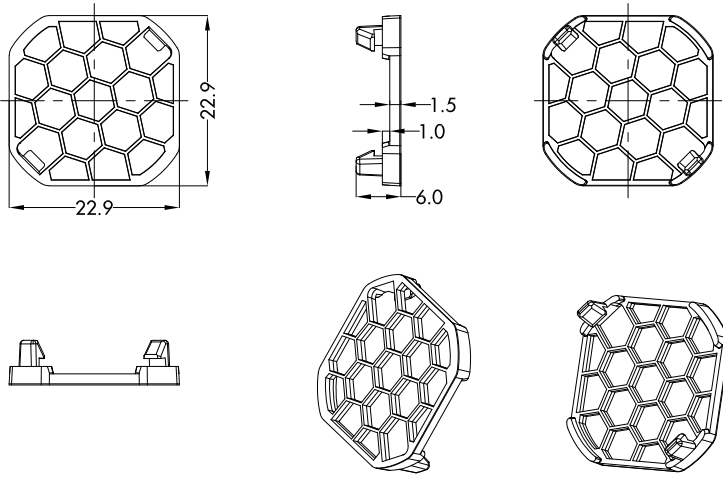

注意/NOTE:

1. 镜片表面应光滑无划痕、气泡、凹痕和黑点。

The surface of the lens should be smooth without scratches, bubbles, dents and black spots.

MATERIL	PC
LINEAR	
$0.5 \leq X \leq 3.0$	± 0.1
$3.0 \leq X \leq 6.0$	± 0.1
$6.0 \leq X \leq 30.0$	± 0.2
ANGULAR	
$0^\circ \leq X \leq 10^\circ$	$\pm 1^\circ$
$10^\circ \leq X \leq 50^\circ$	$\pm 30'$
$50^\circ \leq X \leq 120^\circ$	$\pm 20'$

H888V-P

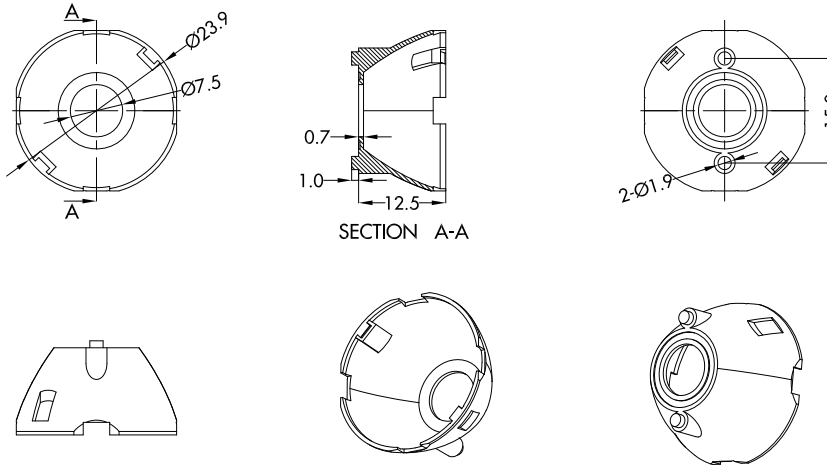

注意/NOTE:

1. 镜片表面应光滑无划痕、气泡、凹痕和黑点。

The surface of the lens should be smooth without scratches, bubbles, dents and black spots.

MATERIL	PC
LINEAR	
$0.5 \leq X \leq 3.0$	± 0.1
$3.0 \leq X \leq 6.0$	± 0.1
$6.0 \leq X \leq 30.0$	± 0.2
ANGULAR	
$0^\circ \leq X \leq 10^\circ$	$\pm 1^\circ$
$10^\circ \leq X \leq 50^\circ$	$\pm 30'$
$50^\circ \leq X \leq 120^\circ$	$\pm 20'$

H888V-T

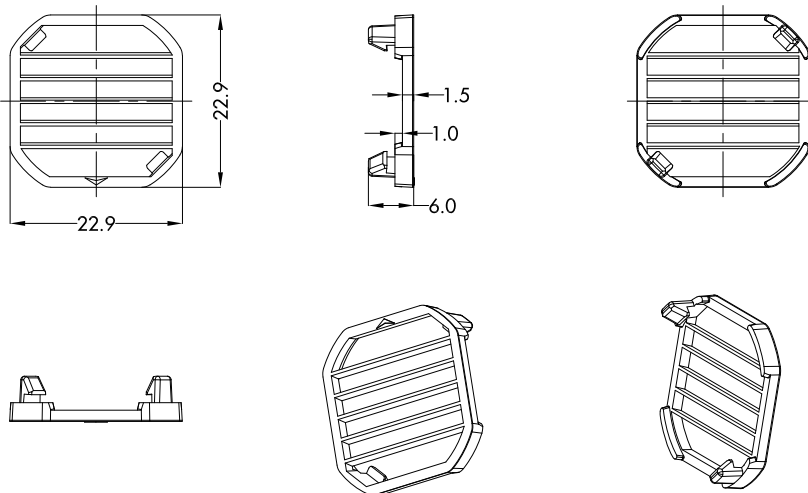

注意/NOTE:

1. 镜片表面应光滑无划痕、气泡、凹痕和黑点。

The surface of the lens should be smooth without scratches, bubbles, dents and black spots.

MATERIL	PC
LINEAR	
$0.5 \leq X \leq 3.0$	± 0.1
$3.0 \leq X \leq 6.0$	± 0.1
$6.0 \leq X \leq 30.0$	± 0.2
ANGULAR	
$0^\circ \leq X \leq 10^\circ$	$\pm 1^\circ$
$10^\circ \leq X \leq 50^\circ$	$\pm 30'$
$50^\circ \leq X \leq 120^\circ$	$\pm 20'$

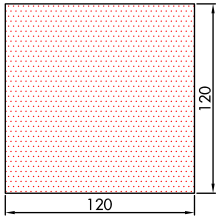

静电纸
MG tissue paper (19g)

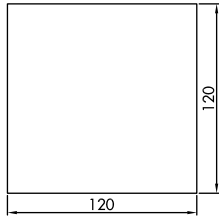

层纸
cardboard (0.4mm)

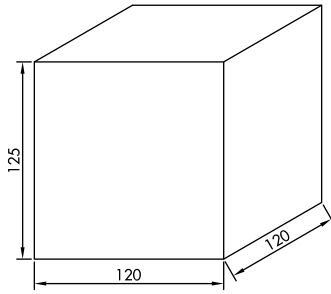

内盒
cardboard box(S)

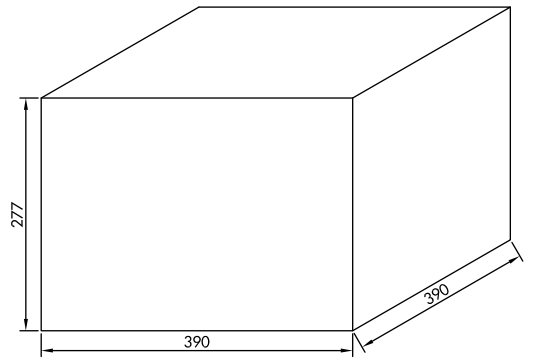

外盒
cardboard box(M) 2:1

型号/Part No.	数量/QTY
IENS888-S23-XX-H888H (V) Mx-3030/3535/5050	4050pcs
静电纸/MG tissue paper (19g)	162pcs
层纸/cardboard (0.4mm)	180pcs
内盒/cardboard box(S)	18pcs
外盒/cardboard box(M)	1pcs

示意图/The schematic diagram:

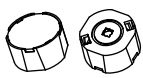

IENS888-S23-XX-H888H (V) Mx-3030/3535/5050
High:12.5mm

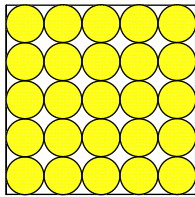

5pcs*5=25pcs

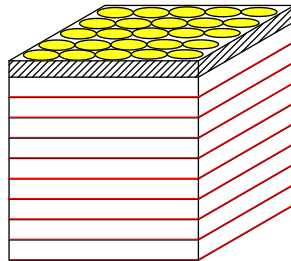

25pcs*9=225pcs

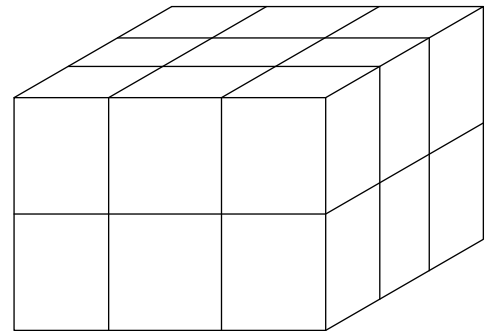

225pcs*18=4050pcs

型号/Part No.	数量/QTY
IENS888-S23-XX-H888VMx-P	4050pcs
静电纸/MG tissue paper (19g)	162pcs
层纸/cardboard (0.4mm)	180pcs
内盒/cardboard box(S)	18pcs
外盒/cardboard box(M)	1pcs

示意图/The schematic diagram:



IENS888-S23-XX-H888VMx-P
High:13.5mm

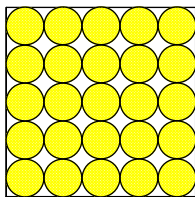

5pcs*5=25pcs

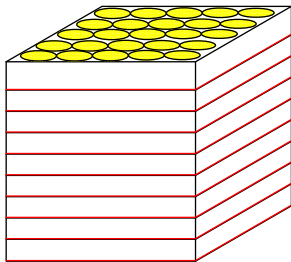

25pcs*9=225pcs

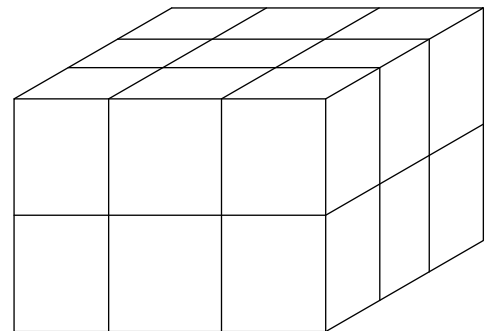

225pcs*18=4050pcs